

ATOS



Industrial High-End 3D Digitizer

3D Coordinate Measurement Machine
CAD Comparison and Inspection
Digitizing of Models and Tools

ATOS

Industrial High-End 3D Digitizer

The ATOS 3D Digitizer delivers three-dimensional measurement data for industrial components such as sheet metal parts, tools and dies, turbine blades, prototypes, injection molded and casted parts. Instead of measuring single points, full part geometry is captured in a dense point cloud or polygon mesh describing the object's surface and primitives precisely.

3D digitizing with the ATOS delivers for different object sizes and complexities:

- Highly accurate 3D coordinates
- Full-field deviation to CAD
- Section-based analysis
- Complete measuring reports

Challenges solved ...

Problem: no CAD data

Solution: ATOS captures complete object surfaces providing a high-resolution polygon mesh. This data is converted to CAD data using reverse engineering techniques.

Problem: product improvement

Solution: ATOS delivers full color inspection reports. These easily readable reports allow an understanding of tendencies and communication of optimization strategies.

Problem: process optimization

Solution: ATOS data enables regular monitoring of product quality. Understanding the as-built conditions helps adjust production machinery, increasing process security.

Problem: actual shape of production tools

Solution: ATOS aids determination of tool changes. The high-quality 3D data allows direct milling on points or reconstruction of CAD surfaces.

The ATOS 3D Digitizer is an accurate and cost-effective solution in a number of different application areas:

- Quality Control
- Reverse Engineering
- Rapid Prototyping
- Rapid Milling
- Digital Mock-Up



Component

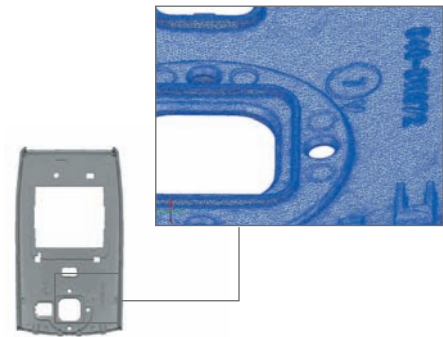

Polygon Mesh

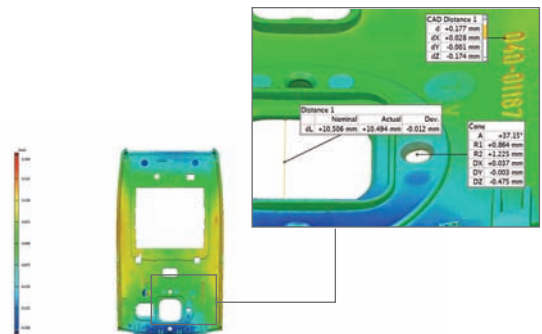

CAD Comparison

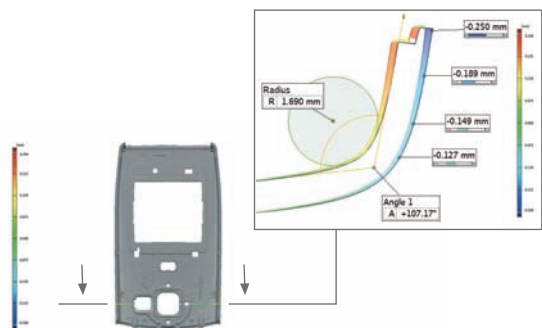

Sectional Analysis

Fringe projection for high-precision 3D coordinate measurement

The ATOS 3D Digitizer is based on the principle of triangulation using a stereo camera setup. This stereo camera setup and a projection unit are integrated in the compact and robust ATOS sensor head.

The sensor projects different fringe patterns onto the object's surface. These patterns are recorded by the two cameras, forming a phase shift based upon sinusoidal intensity distributions on the CCD chips. The ATOS uses multiple phase shifts in a heterodyne principle to achieve highest sub-pixel accuracy. Based on the optical transformation equations, independent 3D coordinates are automatically calculated for each camera pixel. Depending on the camera resolution, a point cloud of up to 4 million surface points results for each measurement.

The geometrical configuration of the ATOS sensor and lens distortion parameters are calibrated using photogrammetric methods. ATOS' proven stereo camera technique delivers, for each measurement, an overdetermined system of equations. This technique allows the ATOS to guarantee process security by:

- Detection of sensor/part movement
- Verification of transformation accuracy
- Identification of environmental changes
- Online tracking of 3D sensor position

Each ATOS system is certified according to the guideline VDI/VDE 2634 Part 2 for optical 3D measuring systems based on area scanning.

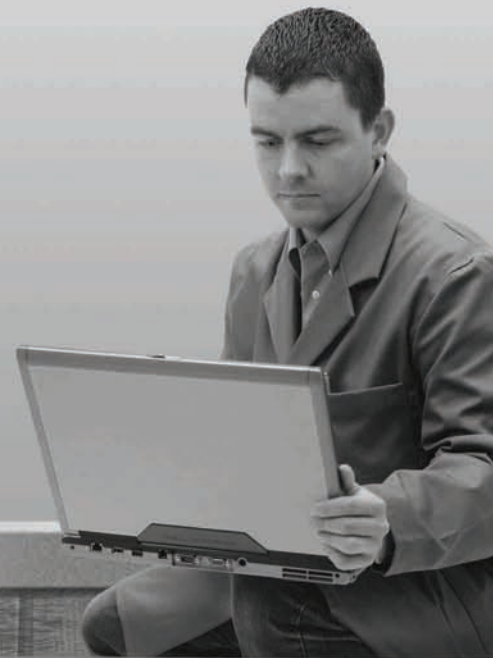

Three-step workflow

Measuring with ATOS is a basic three-step workflow:

- **Sensor positioning and measurement:** The sensor head is freely positioned in front of the component. After each measurement, the sensor or part is moved to obtain areas not captured in the initial scan process. All individual measurements are automatically transformed into a common coordinate system immediately providing the complete 3D point cloud.
- **Evaluation:** The polygon mesh and features such as edges, holes, etc. are mathematically transformed into the coordinate system of the component using RPS, 3-2-1 or Best-Fit registration. The measured and aligned data is used for STL export, CAD comparison, verification of shape and position tolerances, verification of specifications from drawings or files.
- **Reports and results:** The results of the detailed analysis, such as dimensions, sections, primitives and nominal / actual comparison are exported in reports or a number of different data formats.

Industrial advantages for industrial processes

More than 10 years ago, the automotive industry was the driving force for the development of the ATOS full-field digitizing systems. These systems were utilized to capture form information from cars and components for the reverse engineering process to generate CAD models.

Today, the ATOS is used for many industrial measuring applications. Inspection, root cause analysis and quality assurance of sheet metal stampings, machined and formed parts, composite lay-ups, assemblies, interiors and entire vehicles and aircraft are typical applications in the automotive, aerospace and consumer sectors. Other high return on investment areas are prototyping, mold making, tool making, injection molding, die-casting, precision casting, and blow molding applications.

These industrial processes are improved by:

- Complete product control
- Improved quality
- Reduced manufacturing time
- Earlier identification of tendencies
- Higher quantities by product introduction
- Faster from idea to finished product

The industry thus benefits from the ATOS solution by:

- Reduction of product development times
- Enhancement of the process security
- Optimization of production procedures



Complete workflow in one software application

GOM completely develops the ATOS hardware and software in house. The software is used to run the sensor head, to process the 3D point cloud and to edit and post-process the data.

Through a simple graphical user interface, the ATOS software supports today's tasks in quality control, manufacturing processes and reverse engineering.

Sensor control, polygon mesh generation and editing, sectioning, feature line detection, primitive generation are basic software functions. For quality control and result analysis, tools such as CAD data import; import of measuring plans; registration; full-field deviation plots; section-based analysis; deviation of individual points; GD&T; calipers, angles and diameters; report creation are available.

These built-in features enable ATOS to:

- Integrate in automation processes
- Communicate with analysis tools
- Batch process multiple projects

Free result viewer

Full-field measuring data allows for an easy understanding of problematic areas and a faster finding of possible solutions. To support the interaction between measurement, analysis, construction and development department, all data created in ATOS can be bundled in one session file. A free result viewer is available to review the measurement results and to perform simple analysis operations such as editing the representations, creating additional analysis elements and exporting the results in reports.



ATOS

Sensor Technology

ATOS 3D Digitizers have been produced and constantly developed since 1995.

The ATOS 3D Digitizer is a flexible optical measuring machine. With more than 2000 installations in measurement and analysis rooms as well as factory and production halls worldwide, the ATOS has been for a long time an accepted measurement method beside the mechanical measurement machines.

In all sensor generations, GOM applied latest technology and knowledge. A strong development team within GOM is responsible for transforming market experience and customer requirements into a sensor technology meeting high application demands.

The ATOS sensor combines high data quality in short measurement time with flexibility and stability for industrial environments.

Accuracy

The camera support bar which carries the two measurement cameras guarantees high mechanical stability due to design and Finite Element optimization. The carbon fiber construction makes a robust camera setup to achieve highest measurement accuracies even when measuring directly in production environments with uneven floor levels, heavy machinery and rough conditions.

The camera support bar, which has integrated laser pointers for easy stand-off control, can be exchanged by opening four screws and thus offering a complete new range of measuring areas.

Speed

Two million accurate 3D coordinates are measured per second by combining a high-speed slide moving device with the heterodyne fringe projection technique. The slide movement is precisely adjusted during the sensor production within GOM to use maximum camera frequency. Results are available quickly supporting fast problem analysis and a higher project throughput with the same manpower.



Robust

4500 ANSI-Lumen are projected by a high performance light source to achieve strong fringe contrasts even on dark objects. The ATOS can thus measure in harsh environments like production halls and factories with difficult lighting conditions.

This light intensity is also used to properly illuminate very large measuring areas of up to 2m x 2m. The lighting can be controlled in such a way that during one measurement cycle different surface colors can be measured without special adaptation.

Process security

The ATOS constantly controls the sensor setup and environmental conditions and informs the user in case of any influence on measurement quality and accuracy. The use of GOM's proven two camera technology provides this information within each measurement and even before invoking the measurement.

Measurement of small to large objects

The measuring area of the ATOS sensor can be changed within a few minutes to meet optimum resolution for each application.

Simply exchanging the lenses provides the full amount of measurement points in a different area and thus an increased scan data resolution or increased measuring field of view. The software also handles different measuring areas within one project to combine highest resolution in high detail areas with a quick scanning.

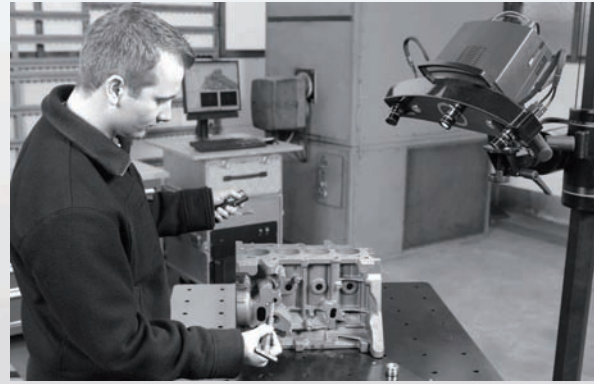
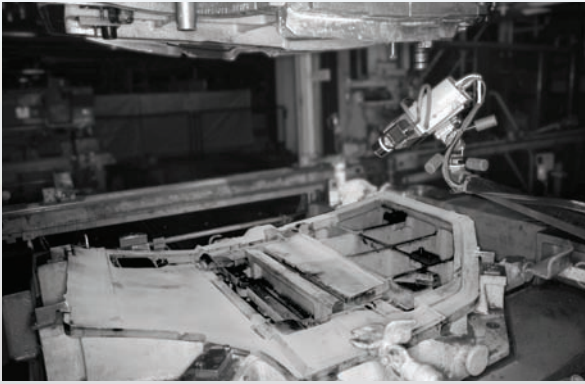

Optically Tracked Touch Probe

The GOM Touch Probe is available as an Add-On to the ATOS 3D Digitizer, combining full-field and touch probe 3D measurement. The GOM Touch Probe allows among other things the measurement in difficult to access areas, comparison directly to CAD, measurement of primitives, quick measurement of individual points and online alignment.

ATOS and Touch Probe measurements are carried out with one system and are evaluated with one software package. No extra hardware or tracker is required, enabling quick measurement procedures and easy interchange between surface and single point measurement and analysis.

Industrial environments and notebook operated sensor

Instead of moving the measurement component to the measuring machine, the ATOS sensor comes to the object. To easily handle and transport the sensor in metrology and analysis rooms as well as production and factory facilities, the controller device is integrated into the sensor head and light-weight and robust cables are used.

As an alternative to a quadcore high powered rack mount PC, the ATOS can be operated directly using a notebook PC. The notebook-based solution combined with a lightweight stand and the transporting suitcase that also holds all other accessories allows easy traveling.

ATOS HR



ATOS II / II SO



ATOS I / I SO



ATOS Std



ATOS HR SO



ATOS IIe / III



ATOS II / II SO
ATOS IIe / III



ATOS

Sensor Variations

The ATOS 3D Digitizers are available in different variations to meet application requirements perfectly. Each sensor type is combined with the full ATOS software providing the quality polygon mesh and extensive post-processing functionalities.

ATOS II

The ATOS II with its compact light sensor head and fast measurement procedure has been developed for the highest degree of flexibility. The available measuring areas span over a large range and can even be extended by switching to the "SO" configuration.

The ATOS II captures the data from the two 1.4 million pixel cameras within 1 second.

ATOS IIe

The ATOS IIe provides an extremely bright light source (4500 ANSI-Lumen) which enables measurements in difficult ambient conditions. Two 1.4 million pixel cameras deliver 3D coordinates even on dark surfaces in rough environments.

The integrated controller reduces the overall number of components and provides a streamlined measuring device.

ATOS III

The ATOS III combines the high performance light source with two 4 million pixel cameras. It allows measuring smallest details with highest resolution and realizing largest measuring areas of up to 2m x 2m.

Using 4 million 3D coordinates in a single measurement provides a time efficient data capture as larger measuring areas with high resolution can be used.



Automation using robots and kinematics

Increasing demands for a higher throughput and reduced cycle time for process optimization require the automation of measurement and evaluation.

For an efficient automation, GOM develops, supplies and supports:

- Measuring hardware
- Sensor and robot control
- Scanning software
- Data handling and editing
- Import of nominal data and measuring plans
- CAD comparison
- Inspection reporting

For repeated measurements, automation devices like robots, rotation tables or linear units are used to handle the sensor head or measurement object. A macro is recorded within the ATOS software containing the device's positions, sensor controls and all processing steps. Additional measurements of the same part geometry are repeated automatically by invoking the measurement macro with the play button.

ATOS macros are based on a scripting language. The standard use is a record and play procedure. For advanced applications, an editing level is available to perform e.g. conditional loops, sub-macro calls and operating system actions.

Technical Data			
System Configurations	ATOS II	ATOS IIe	ATOS III
Measured Points	1 400 000 in 1s	1 400 000 in 1s	4 000 000 in 2s
Measurement Time	1 second	1 second	2 seconds
Measuring Area (min.)	175 x 140 mm ²	175 x 140 mm ²	150 x 150 mm ²
Measuring Area (max.)	2000 x 1600 mm ²	2000 x 1600 mm ²	2000 x 2000 mm ²
Point Spacing	0.12 - 1.4 mm	0.12 - 1.4 mm	0.07 - 1.0 mm
Stand-Off	730 - 2000 mm	730 - 2000 mm	760 - 2800 mm
Brightness	400 ANSI-Lumen	4500 ANSI-Lumen	4500 ANSI-Lumen
Camera Pixels	2 x 1 400 000	2 x 1 400 000	2 x 4 000 000
Sensor Dimensions	490 x 260 x 170 mm ³	490 x 300 x 170 mm ³	490 x 300 x 170 mm ³
Sensor Weight	5.2 kg	7.0 kg	7.4 kg
Positioning Pointers	•	•	•
High-End PC	•	•	•
Notebook	•	•	•
Sensor Controller	external	integrated	integrated
Automation	•	•	•
Variable Workstation	•	•	•
Cable Length		up to 30m	
Transport Case		550 x 800 x 300 mm ³ , 32kg	
Operating Temperature		0° - 40°C	
Humidity		non-condensing	
Power Supply		90 - 230V AC	

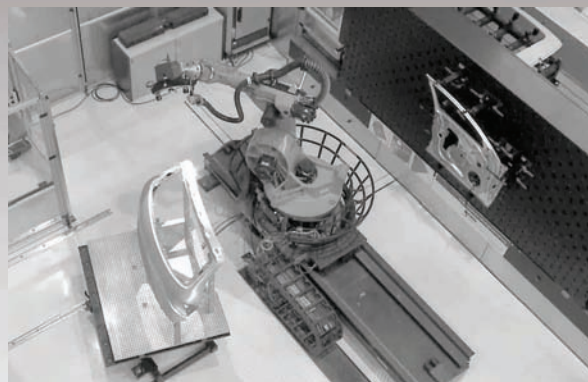
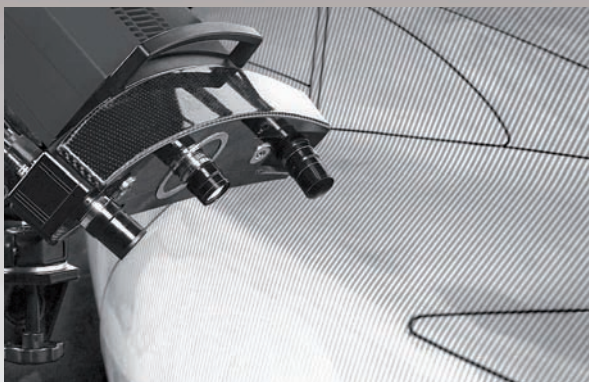

ATOS SO

High-End 3D Digitizer for Small Objects

The ATOS SO ("Small Objects") series is a dedicated solution for precisely measuring small objects such as injection molding components, medical parts, smallest turbine blades.

The SO systems are mainly used for complex small parts with high demands on accuracy and data quality. With point distances of less than 0.02 mm even smallest details can be measured.

The ATOS SO systems are typically used as a table-top device. The sensor head is positioned together with the measuring object in a stable setup, the two measuring cameras are mounted in front of the sensor head. Combining camera positions and focal lengths of camera and projection lenses create an optimized triangulation for smallest measuring areas.

The ATOS SO sensor head is mounted on a vertical translation unit to quickly adjust the working distance to the measurement object. A motorized rotation table, macro programming and an interchangeable object holder lead to the automation of the complete workflow including part positioning.

From small to large objects

The ATOS SO series is fully compatible with other ATOS solutions. Changing the camera support bar, allows to switch from smallest measuring areas to the largest measuring area within a few minutes.

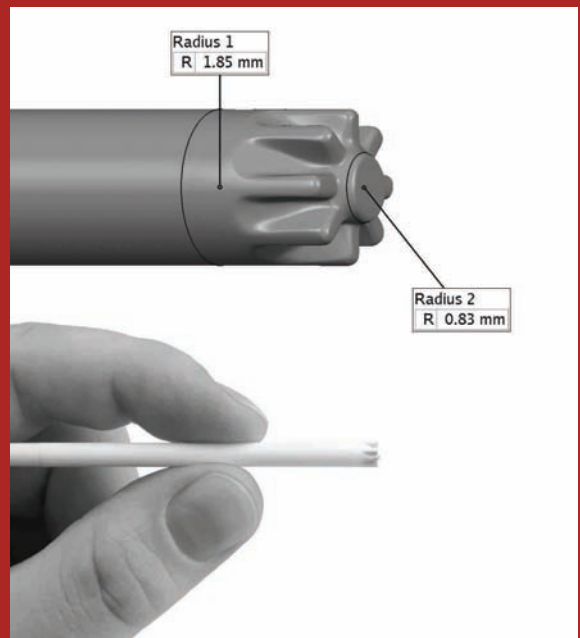

Technical Data

System Configurations	ATOS II SO	ATOS SO 4M
Measured Points	1 400 000 in 1s	4 000 000 in 2s
Measurement Time	1 second	2 seconds
Measuring Area (min.)	30 x 24 mm ²	30 x 30 mm ²
Measuring Area (max.)	250 x 200 mm ²	300 x 300 mm ²
Point Spacing	0.02 - 0.17 mm	0.015 - 0.15 mm
Stand-Off	280 - 390 mm	280 - 430 mm
Camera Pixels	2 x 1 400 000	2 x 4 000 000
Sensor Dimensions	300 x 260 x 170 mm ³	300 x 300 x 170 mm ³
Positioning Pointers	•	•

Development, construction, support all in one

The "Gesellschaft für Optische Messtechnik" (GOM) develops, produces and distributes optical measuring equipment for the three-dimensional measurement and deformation measurement of components. The measuring systems are based on digital image processing and are used in product development, quality assurance, material and component testing.

All over the world, companies of the automotive, aviation and space industries, their suppliers and various manufacturers of consumer goods use GOM systems.

GOM was founded in 1990 as spin-off of the Technical University Braunschweig, Germany. The company owns subsidiaries in Switzerland, France, Great Britain and Belgium. Worldwide, more than 30 committed and competent partners install, support and market GOM products.

Today, GOM offers a complete in-house solution covering hardware, software, technical support and training.

GOM customers (extract)

ABB • Adidas • AE Group • Air Force Research Labs • Airbus • Alcan • Alcoa • Alfa Laval • Alstom • Amphenol Phoenix • Apache Footwear • Arcelor • Army Research Lab • Aselsan • Asics • Asus • Audi • Auto Parts Malaysia • Autodie • Autoliv • Automotive Lighting • Autopal • Avtovaz • Balda • BAM • Bang&Olufsen • BASF • Batz • Bayer • Bentley • Bertone • Bertrandt • Blaupunkt • BMW • Boeing • Bombardier • Bosch • BPlas • Braun • Bridgestone • Bundeskriminalamt • Busch Jäger • Carsun • Carlton Forge • Caterpillar • Cersanit • Cessna • Ching Luh Shoes • Chromalloy • Cimos • Corning • CTA • Centre Tecnològic Manresa • DAAZ • Daewoo • Daimler • Delloyd • Delphi • DLR • Dräxlmaier • DuPont • EADS • Ecco • Elasis • Elbar Sulzer • Embraco • Endo Manufacturing • E.ON • Etimex • Eurocopter • Ever Tech • Exxon • Eybl • FAG Schäffler • Fagus • Faurecia • Federal Aviation Administration • FES • Fiat • First Automobile Group • FisherPrice • Flextronics • Ford • Forschungszentrum Karlsruhe • Foxconn • Fraunhofer Gesellschaft • Fuji • Gabor • General Electric • General Motors • Georg Fischer • Goodrich • Goodyear • Gorbynov Aviation • Green Point • Halliburton • Head Tyrolia • Hella • Henkel • Hilti • Hitachi • Taga • Honda • Honeywell • Howmet • Hydro • Hyundai • IAV • Imperial College • IMPO • International Automotive Research Centre • Intier • Istanbul Technical University • Isuzu • Italdesign-Giugiaro • IUC • IVM • Jaguar • Jhi Soon Auto Metal • Jiaotong University • John Deere • Johnson Controls • Kaitech • Kautex

Textron • Kewpump • Kia • KTM • Kuka Systems • Land Rover • Läßle • Laurence Livermore National Labs • Lego • Los Alamos • LUK • Luxottica • Magna • Magueti Marelli • Mahle • Maserati • Matador • Materialise • Matrici • Mattel • Max Planck Institute • McLaren • Mercedes Benz • Metalbages • Michelin • Microsoft • Modenas • Montupet • MTU • Nagasaki Industrial Research Center • NASA • Naval Research Lab • NAZA • Nemak • Nike • Nissan • Nokia • Nolato • Northrop Grumman Systems • Nothelfer • Nottingham University • Nypro • OLHO Technik • Olympus • ONERA • Opel • PCCL • PCI • Peguform • Penske Racing • Phiaro • Philips • Pierburg Kolbenschmidt • Pilkington • Pininfarina • Playmobil • Playworks • Porsche • Pratt & Whitney • PSA • Queen Mary College • Quipplan • Rautenbach • Renault • Robbe&Berking • RollsRoyce • Rotax • Ruukki • RWTH Aachen • Saint-Gobain • Saipa • Salzgitter • Sandvik • Sea Ray • Seat • Shenyang Aircraft Research Institute • Siemens • Skoda • SKS Coachbuilders • SLG • Snecma • Solar Turbines • Solvay • SonyEricsson • Standard Profile • Steyr Daimler Puch • Stola • Subaru • Sun Microsystems • Suzuki • Tata Motors • Tata Steel • Temsa • Thyssen • Tianjin Motor Dies • Tokai Rubber Industries • Topia • Toyota • Triumph • TRW • Tubitak Marmara Research Center • Turbine Services • Valeo • VDO • Villeroy&Boch • Visteon • Voest Alpine Stahl • Volke • Volkswagen • Volvo • Volvo Aero • Vulcan Air • VZLÚ • Walt Disney • Warwick University • Yulon

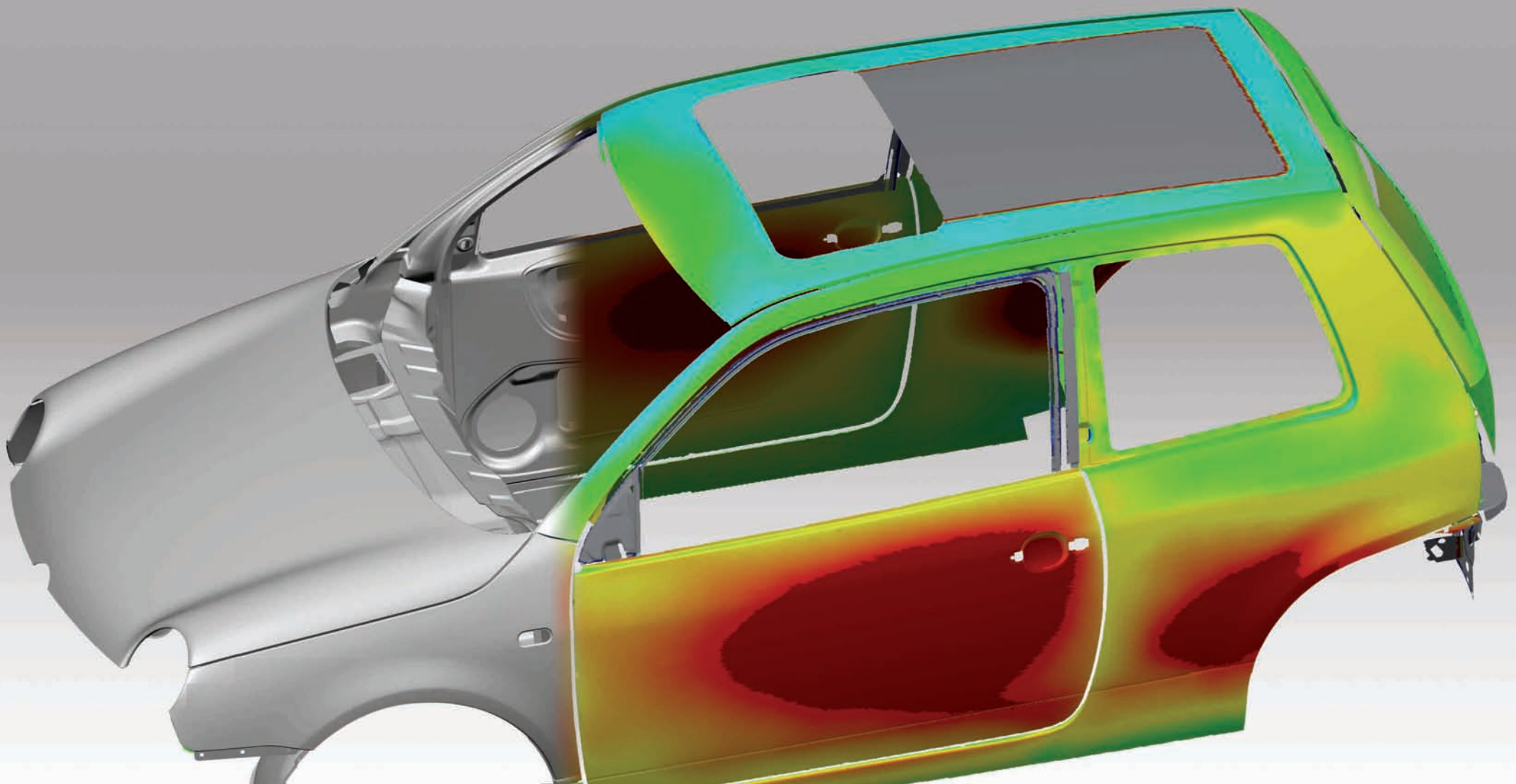



Worldwide support network

Argentina

ROBTEC ARGENTINA
Phone +54 11 4787 6800
info@robtec.com

Australia

MOSS Pty Ltd
Phone +61 3 9946 1086
scan3d@iprimus.com.au

Austria

Westcam Datentechnik GmbH
Phone +43 5223 5550 90
office@westcam.at

Belarus, Russia, Ukraine

MCP Technology
Phone +375 17 262 5612
mcp@technology@mcp.by

Brazil

ROBTEC DO BRASIL
Phone +55 11 3318 5100
info@robtec.com

China

Pro-Technic Machinery Ltd.
Phone +852 2428 2727
atd@protechnic.com.hk

Croatia, Slovenia

Topomatika d.o.o.
Phone +385 91 5046 239
info@topomatika.hr

Czech Republic

MCAE Systems s.r.o.
Phone +420 549 128 811
mcae@mcae.cz

Denmark

Zebicon
Phone +45 7650 9152
info@zebicon.com

Finland

Cascade Computing AB
Phone +358 40 515 3341
info@cascade.fi

Greece

EXPERTCAM
Phone +30 210 2757 410
exp@cam@otenet.gr

India

APM Technologies
Phone +91 11 4163 1416
apmtech@vsnl.net

Indonesia

PT Henindo
Phone +62 21 489 9675
henvgs@attglobal.net

Iran

Fadak Sanat Gostar (FSG)
Phone +98 21 88 730 735
info@fadaksanat.com

Italy

MICROSYSTEM SRL
Phone +39 051 4145611
info@microsystem.it

Japan

Marubeni Solutions Corp.
Phone +81 3 5778 8571
Sato-Yoshiyuki@marubeni-sys.com

Malaysia

First High Tech Sdn Bhd
Phone +603 7665 2188
info@1st.com.my

Mexico

CIM Co.
Phone +52 55 5565 6633
info@cimco.com.mx

Pakistan

Ultimate CAD Solutions Ltd
Phone +92 51 5467572
shakir@ucs-int.com

Poland

ITA
Phone +48 61 843 6344
info@ita-polska.com.pl

Portugal

S3D
Phone +35 12 4457 3100
suporte@s3d.pt

Romania

SPECTROMAS SRL
Phone +40 21-3105190
info@spectromas.ro

South Africa

RGC Engineering Pty
Phone +27 11 531 0766
info@rgcengineering.co.za

South-Korea

OMA Co.
Phone +82 42 822 9501
support@omagom.co.kr

Spain

Metronic S.A.
Phone +34 943 121400
comercial@metronicnet.com

Sweden

Cascade Computing AB
Phone +46 31 84 0870
info@cascade.se

Taiwan

Road Ahead Technologies
Phone +886 2 2999 6788
marcel@rat.com.tw

Thailand

Mentel Co., Ltd.
Phone +66 2274 0694 98
info@mentel.co.th

Turkey

Cadem A.S.
Phone +90 216 557 64 64
gom@cadem.com.tr

USA

Capture 3D Inc.
Phone +1 714 546 7072
support@capture3d.com

USA

Trillion Quality Systems LLC
Phone +1 610 722 5100
info@trillion.com

Venezuela

AT Group Software Inc
Phone +58 212 9432 446
dkinz@atgroup.com.ve

Vietnam

AIE
Phone +84 47 345435
aie@vnn.vn



GOM mbH

Mittelweg 7-8
38106 Braunschweig
Germany
Phone +49 531 390 29 0
Fax +49 531 390 29 15
info@gom.com

www.gom.com

GOM International AG

Bremgarterstrasse 89B
8967 Widen
Switzerland
Phone +41 5 66 31 04 04
Fax +41 5 66 31 04 07
international@gom.com

GOM France SAS

10 Quai de la Borde - Bât A2
91130 Ris Orangis
France
Phone +33 1 60 47 90 50
Fax +33 1 69 06 63 60
info-france@gom.com

GOM UK Ltd

Business Innovation Centre
Coventry, CV3 2TX
Great Britain
Phone +44 2476 430 230
Fax +44 2476 430 001
info-uk@gom.com

GOM Branch Benelux

Interleuvenlaan 15 E
3001 Leuven
Belgium
Tel +32 16 408 034
Fax +32 16 408 734
info-benelux@gom.com